

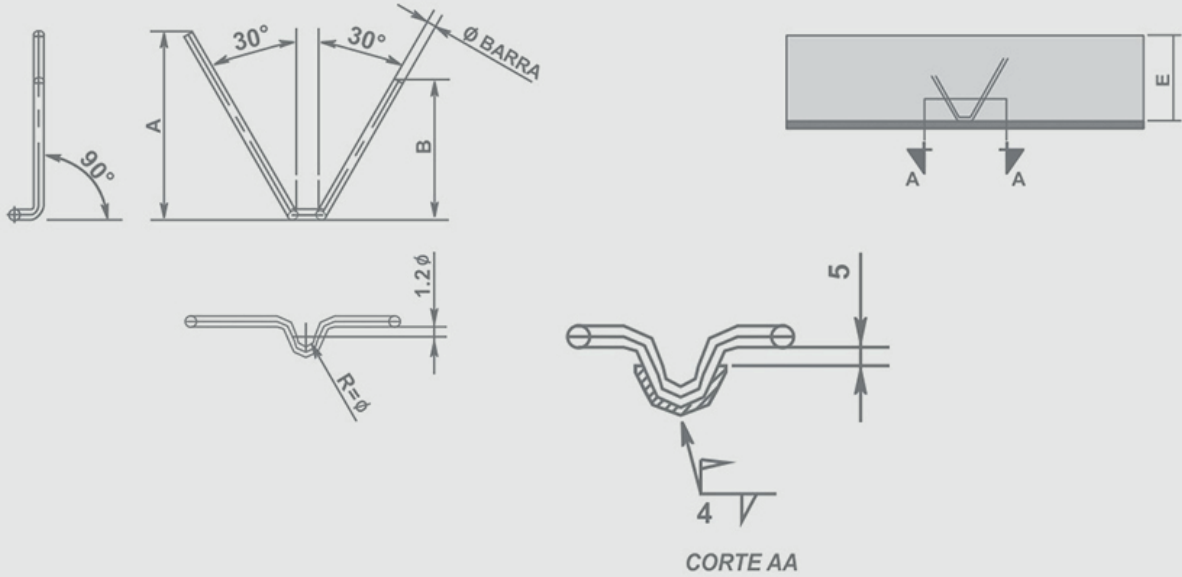

ÂNCORAS
METÁLICAS



ÂNCORAS METÁLICAS



ARRANJO DAS ANCORAGENS

E - Espessura do Revestimento

PAREDES A = 2E a 3E para E < 100mm.

A = 200 a 300mm para E > 100mm.

TETOS

A = 2E máximo 200mm.

E	Ø BARRA	A	B
50	3/16"	33	25
63	3/16"	42	32
75	3/16"	50	38
90	1/4"	60	45
100	1/4"	66	50
113	1/4"	75	57
125	1/4"	83	63
150	1/4"	100	75
>150	5/16	2/3E	1/2E

E - Espessura Total do Revestimento.

Dimensões em milímetros (exceto quando indicado).

Tolerância geral ± 5%.